

REV	DESCRIPTION	Section	Engineer	Checked	Date

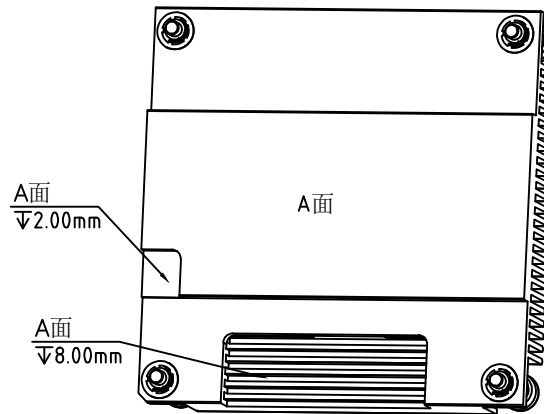
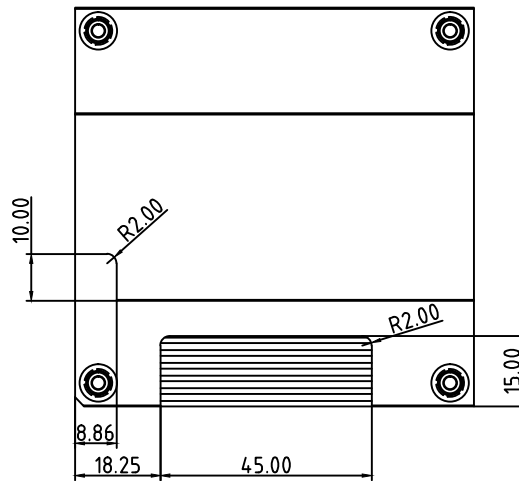
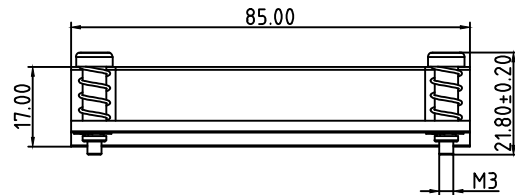
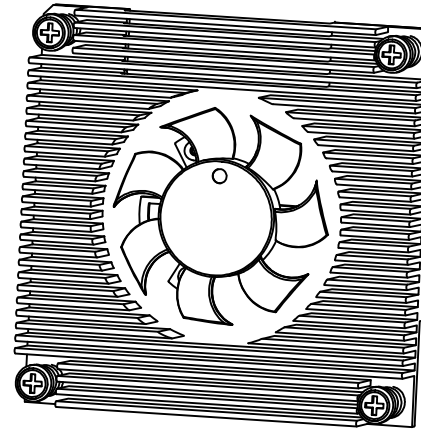
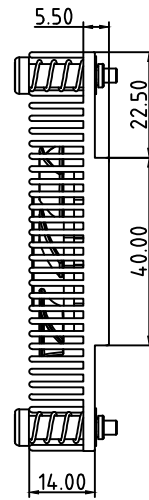
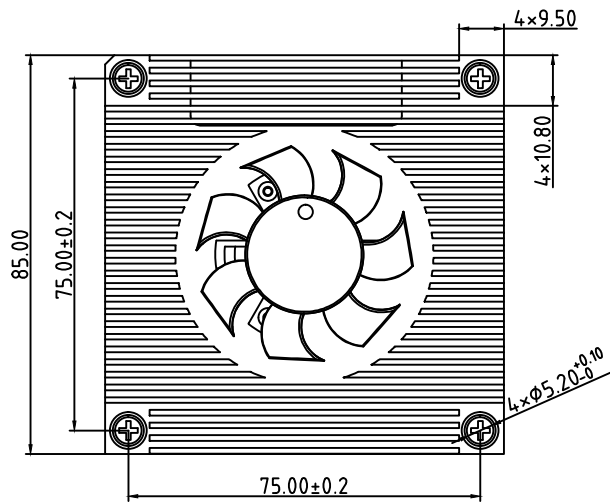

技术要求:

1. 材质:AL 6063 T5
2. 材质硬度:68~75Hv
3. 表面处理:阳极哑黑
4. 未标注之圆角为0.2
5. 产品不可有刮压伤,歪齿,刀痕,毛刺,脏污,裂痕.
6. 理论单重:g 理论毛重:g
7. 铝挤料号:
8. 标示符号①~⑩的为重点检验尺寸
9. 所有物料和制程需符合RoHS要求.

Cool Solte Co.,Ltd  
正式图面  
DATE  
2021/3/23

		东莞市硕泰电子科技有限公司 Dong Guan Solte Electronics Technology Co.,LTD					东莞市大岭山镇矮岭冚创业三街2号 TEL: 86-769-81836450 FAX: 86-769-81836453	
ENGINEER:	林占海	0 ~	0.07	0.10	0.10	0.15	0.20	0.30
DATE:	2021/3/23	30						
CHECKED:	杨进林	10 ~	0.08	0.15	0.20	0.25	0.30	0.40
DATE:	2021/3/23	50						
APPROVED:		50-100	0.09	0.20	0.25	0.30	0.40	0.50
DATE:		100-200	0.15	0.25	0.30	0.35	0.50	1.00
APPROVED:		200 ~	0.20	0.30	0.35	0.40	0.60	1.50
DATE:		Angles	1°	1°	1°	1°	2°	3°
Scale	1:1	Sheet-d/Unit	1/1	mm	Size	A4	Revision	A1

Part Name: Heat Sink  
Part Number: STH-0625  
Customer (DW) Number: N/A